

Bravura™
Two Manual Classical
L-6

Bravura L-6
Copyright © 2015 Allen Organ Company LLC
All Rights Reserved

ALLEN ORGAN COMPANY

For more than sixty years--practically the entire history of electronic organs-- Allen Organ Company has built the finest organs that technology would allow.

In 1939, Allen built and marketed the world's first electronic oscillator organ. The tone generators for this instrument used two hundred forty-four vacuum tubes, contained about five thousand components, and weighed nearly three hundred pounds. Even with all this equipment, the specification included relatively few stops.

By 1959, Allen had replaced vacuum tubes in oscillator organs with transistors. Thousands of transistorized instruments were built, including some of the largest, most sophisticated oscillator organs ever designed.

Only a radical technological breakthrough could improve upon the performance of Allen's oscillator organs. Such a breakthrough came in conjunction with the United States Space Program in the form of highly advanced digital microcircuits. In 1971, Allen produced and sold the world's first musical instrument utilizing digitally sampled voices!

Your organ is significantly advanced since the first generation Allen digital instrument. Organs with Renaissance™ technology are the product of years of advancements in digital sound and control techniques by Allen Organ Company. This system represents the apex of digital technology applied to exacting musical tasks. The result is a musical instrument of remarkably advanced tone quality and performance.

Congratulations on the purchase of your new Allen Organ! You have acquired the most advanced electronic organ ever built, one that harnesses a sophisticated custom computer system to create and control beautiful organ sound. Familiarize yourself with the instrument by reading through this booklet.

Contents

I.	ORGAN STOPS	2
II.	SPECIALIZED STOP CONTROLS	3
III.	EXPRESSION SHOES.....	4
IV.	SETTING PISTONS.....	4
V.	ARTISTIC REGISTRATION	5
VI.	TRANSPOSER.....	9
VII.	VIRTUAL ACOUSTICS™.....	9
VIII.	SOUND LIBRARY	10
IX.	INSTALLATION, VOICING, AND CARE OF THE ORGAN	10
X.	SAFETY INFORMATION	11
XI.	CONSOLE CONTROLLER™ GUIDE	13

I. ORGAN STOPS

PITCH FOOTAGE

The number appearing on each stop, along with its name, indicates the “pitch” or “register” of the particular stop. Organs can produce notes of different pitches from a single playing key. When this sound corresponds to the actual pitch of the played key, the stop is referred to as being of 8’ (eight foot) pitch; therefore, when an 8’ stop is selected and Middle C is depressed, the pitch heard is Middle C. If the sounds are an octave higher, it is called 4’ or octave pitch. If two octaves higher, it is called 2’ pitch. A stop sounding three octaves higher is at a 1’ pitch. Similarly, a 16’ stop sounds an octave lower and a 32’ stop two octaves lower.

Stops of 16’, 8’, 4’, 2’ and 1’ pitch all have octave relationships, that is, these whole numbered stops all sound at octaves of whatever key is depressed. Non-octave pitches are also used in organs. Their footage numbers contain a fraction and they are referred to as *Mutations*. Among these are the 2-2/3’ *Nasard*, 1-3/5’ *Tierce*, 1-1/3’ *Quintflöte* and 2-2/3’ *Twelfth*. Because they introduce unusual pitch relationships with respect to the 8’ tone, they are most effective when combined with other stops and used either in solo passages or in small ensembles of flutes.

TONAL FAMILIES

1. Flues

Organ tones divide into two main categories: *flues* and *reeds*. In pipe organs, flue pipes are those in which the sound is set in motion by wind striking directly on the edge of the mouth of the pipe. Flues include principal, flute and string tones. Compound stops and hybrid stops are variations within these three stop families.

The term “imitative” means that the organ stop imitates the sound of a corresponding orchestral instrument; for example, an imitative 8’ Viola stop sounds like an orchestral viola.

<u>Principal Voices:</u> Principal, Diapason, Octave, Fifteenth, Quinte	Characteristic organ tones, not imitative of any orchestral instruments. Usually present at many pitches and in all divisions. Rich, warm and harmonically well developed.
<u>Flute Voices - Open:</u> Harmonic Flute, Koppelflöte, flute mutation stops <u>Flute Voices - Stopped:</u> Holzgedackt, Bourdon, Lieblichgedackt, Rohr Bourdon	Lesser harmonic development than Principals. Open flutes are somewhat imitative; stopped flutes are not. Present at all pitch levels and in all divisions.
<u>String Voices:</u> Gamba, Salicional, Viole Celeste	Mildly imitative and brighter harmonic development than Principals. Usually appear at 8’ first; can be 4’ & 16’ ranks.
<u>Compound Voices:</u> Mixture, Fourniture	Voices produced by more than one rank sounding simultaneously. Best registered with other stops.
<u>Hybrid Voices:</u> Erzähler, Spitzflöte	Voices that combine the tonal characteristic of two families of sound, e.g., flutes and principals, or strings and principals.

2. Reeds

In *reed* pipes, a metal tongue vibrates against an open flattened side of a metal tube called a shallot. The characteristic sounds of different reeds are produced through resonators of different shapes. The family of reeds subdivides as follows:

<u>Chorus or Ensemble:</u> Basson, Trompette, Posaune, Clarion, <u>Solo:</u> Hautbois, Clarinet, Krummhorn	Voices of great harmonic development; some are imitative of their orchestral counterparts.
---	--

Your Allen Organ provides authentic, digitally sampled voices. They are protected by copyrights owned by the Allen Organ Company and are stored in memory devices, each having affixed to it a copyright notice; e.g., © 2003 AOCO, © 2001 AOCO, etc., pursuant to Title 17 of the United States Code, Section 101 et seq.

II. SPECIALIZED STOP CONTROLS

Some organ stop controls do not turn voices on/off, but instead turn on/off console functions such as outlined in this Section.

MIDI on Pedal	Opens MIDI channel to the Pedal.
MIDI on Swell	Opens MIDI channel to the Swell
MIDI on Great	Opens MIDI channel to the Great.
Tremulant	This stop provides a vibrato effect, natural in the human voice and wind instruments.
Melody Coupler	When playing on the Great manual, the highest key played on the Great will automatically play all stops drawn on the Swell, in addition to those drawn on the Great. By choosing a stop such as the Trompette, the melody played by the top note on the Great is accentuated.
Bass Coupler	Similar to the Melody coupler, however, in this case the lowest note played on the Great will also play all stops drawn in the Pedal Division. This allows voices normally played from the pedalboard to be heard without using the pedalboard.
Gt-Pd Unenclosed	When engaged, the expression shoe will express only the Swell Division. The expression for the Great and Pedal Divisions is disabled, causing the Great and Pedal stops to sound at full volume, regardless of the position of the expression shoe.
Console Speakers Off	This control disables the internal console speakers. If engaged while the External speaker control is engaged, the organ will not sound.
External Speakers Off	This control disables the external speakers connected to the organ. If engaged while the internal speaker control is engaged, the organ will not sound.

8' Great to Pedal	Connects all Great Division voices to the pedalboard at the pitch indicated on the Great stops.
8' Swell to Pedal	Connects all Swell Division voices to the pedalboard at the pitch indicated on the Swell stops.
8' Swell to Great	Intermanual coupler connecting most Swell stops to the Great manual at the Swell stop's indicated pitch.

III. EXPRESSION SHOES

The organ's control pedals (called "shoes") control expression. The L-6 includes a single shoe which controls expression (volume) of all divisions.

IV. SETTING PISTONS

Your Allen Organ's capture system lets you set stop registration combinations in each of its available capture memories. The L-6 has a set of six (6) General pistons located under the left side of the Swell manual and four (4) Divisional pistons for both the Swell and Great divisions centrally located under both the Swell and Great manuals.

SETTING GENERAL PISTONS

General pistons will affect all stops in any division. Any stop turned on will be set within a General piston registration. To set a General piston:

- ❑ First, turn on any stops you wish to save within a registration.
- ❑ Press and hold the **SET** Piston.
- ❑ Press and release the desired GENERAL piston.
- ❑ Finally, release the **SET** Piston.

Note: General pistons are customarily set from soft to loud using graduated stop combinations.

SETTING DIVISIONAL PISTONS

Divisional pistons are different in that they only affect the stops of a single division. For example, only the Swell stops can be programmed onto a Swell divisional piston. Any Great stops turned on while selecting or setting a Swell divisional piston will be unaffected or changed. To set a Divisional piston:

- ❑ First, only turn on stops within a single division you wish to save within a registration.
- ❑ Press and hold the **SET** Piston.
- ❑ Press and release the desired DIVISIONAL piston.
- ❑ Finally, release the **SET** Piston.

The pistons, General or Divisional, which have been set "remember" the registration combinations which have been assigned to each of them. Each time a given piston is pressed, the registration assigned to it is activated. Stop registration combinations may be changed at any time by repeating the above procedures.

V. ARTISTIC REGISTRATION

(Trained organists might not need to review this section.)

Organ registrations fall into two broad categories: solo combinations and ensembles. A solo combination is one in which a melody is played on one keyboard, the accompaniment on another keyboard, and the pedal often provides a light bass line. Almost any stop or combination of stops will sound good as a solo voice. A contrasting tone quality should be chosen for the accompaniment, so that the accompaniment is softer than the solo voice. The pedal stops must provide a foundation for the sound without covering it.

Most 8' reed stops make interesting solo voices. The addition of a 4' flute or a flute mutation (e.g., Nasard or Tierce) to a reed such as the Trompette colors the sound further and increases its volume slightly. Adding an 8' flute to a reed will add body to the sound.

Flutes can be used alone or in combinations as solo voices. One special combination of flutes that creates an appealing and historically significant solo combination is the Cornet (pronounced kor-NAY). The Cornet is created by using Swell flute stops at these pitches: 8', 4', 2-2/3', 2' and 1-3/5'. This combination was used widely in Baroque organ music, but it is just as appropriate for some modern music. Useful variations of the Cornet may be achieved by eliminating the 4', the 2', or both.

When choosing stops for a solo voice, it is not always necessary to include an 8' stop. For example, since the 4' flute has a tone quality different from that of the 8' flute, the 4' flute can be used as an independent solo voice. By playing the solo an octave lower than written, the notes will sound at the correct pitch. In similar fashion, a 16' stop can be selected and the notes played an octave higher than written. Tonal variety will be gained, because each stop has its own tone color.

For accompaniment, the most desirable voices are the 8' flutes or strings on each manual. Celestes often make effective accompaniments. The correct choice depends on the volume of the solo tone (a soft solo voice requires the softest accompanimental stop), the element of contrast, and the location of the solo stop. A bright, harmonically rich solo reed, for example, can be accompanied by either a string or flute, but the flute will often contribute greater interest because of its greater contrast.

Seek a "natural" balance of volume between solo and accompaniment. This will be especially easy to accomplish if the solo and accompaniment are under separate expression.

TWO-MANUAL SUGGESTED SOLO REGISTRATIONS

CHIMES SOLO

Swell: Salicional 8 or Viole 8', Voix Celeste or Viola Celeste 8' or Voix Celeste 8'
Great: Chimes
Pedal: Lieblich Gedackt 16, Swell to Pedal
Play solo on Great.

SOLO CORNET COMBINATION

Swell: Gedackt 8', Koppelflöte 4', Nasat 2-2/3', Blockflöte 2',
Tierce 1-3/5'
Great: Harmonic Flute 8' or Flute Celeste II 8'
Pedal: Lieblich Gedackt 16', Flute 8'
Play solo on Swell.

FLUTE SOLO

Swell: Salicional or Viole 8', Voix Celeste or Viola Celeste 8'
Great: Harmonic Flute 8'
Pedal: Lieblich Gedackt 16', Swell to Pedal
Play solo on Great.

TRUMPET SOLO

Swell: Trompette 8'
Great: Diapason 8' or Principal 8', Octave 4', Fifteenth 2' or Super Octave 2'
Pedal: Bourdon 16', Octave 8', Choral Bass 4'
Play solo on Swell.

These few combinations demonstrate basic techniques of solo registration. In creating registrations of your own, remember these three simple rules:

1. Seek tonal contrast between solo and accompaniment.
2. Be sure the solo is louder than the accompaniment.
3. Choose a solo whose character is appropriate to the specific piece.

ENSEMBLE REGISTRATIONS

Ensemble registrations involve groups of stops that are played together, usually, but not always, with both hands on one keyboard. They are characterized by compatibility of tone, clarity, and occasionally power. Such registrations are used in hymn singing, choir accompaniments, and much of the contrapuntal organ literature.

Ensembles are created by combining stops. Two factors to be considered are: tone quality and pitch. Ensembles begin with a few stops at 8' pitch and expand "outward" in pitch as they build up. New pitches are usually added in preference to additional 8' stops.

Ensembles are generally divided into three groups or "choruses":

The Principal Chorus, the most fully developed, is represented in most divisions of the organ and at pitches from 16' (Diapason) to high mixtures. The Principal chorus is sometimes called the narrow-scale flue chorus, a reference to the relative thinness of principal pipes in relation to their length.

The Flute Chorus is also well represented with a diversity of stops at various pitches. Generally speaking, the Flute chorus is composed of less harmonically developed tones, and is smoother and of lesser volume than the Principal chorus. The Flute chorus is sometimes called the wide-scale flue chorus, owing to the generally "fatter" look of Flute pipes as compared to Principals.

The Reed Chorus includes those reed tones designed to be used in the ensemble buildup. Not all reed voices are ensemble tones. An Hautbois, for example, is usually a solo stop. The various Trumpets, Clairons, Posaunes, etc., are ensemble voices that add brilliance, power, and incisiveness to the sound.

The Swell Reed Chorus of Basson 16' and Trompette 8' represents an entity important to French organ music and the full ensemble of the organ. These stops create a "blaze" of harmonic richness that tops off the Principal and Flute choruses.

Another special ensemble combination important in French music is the **Cornet**, which was discussed in the section on solo registration. This combination can be used with the chorus reeds and mutations to create the "Grand Jeu." The Cornet is also useful in Romantic ensembles to add weight and thickness to the sound.

Here are typical ensemble combinations for the Swell, Great and Positiv manuals:

GREAT

1. Harmonic Flute 8', Spitzflöte 4'
2. Harmonic Flute 8', Spitzflöte 4', Fifteenth 2' or Super Octave 2'
3. Principal 8', Octave 4'
4. Principal 8', Octave 4', Fifteenth 2' or Super Octave 2'
5. Principal 8', Octave 4', Fifteenth 2' or Super Octave 2', Mixture IV
6. Principal 8', Harmonic Flute 8', Octave 4', Spitzflöte 4', Fifteenth 2' or Super Octave 2', Mixture IV

SWELL

1. Gedackt 8', Viöle 8'
2. Gedackt 8', Viöle 8', Koppelflöte 4'
3. Gedackt 8', Viöle 8', Koppelflöte 4', Blockflöte 2'
4. Gedackt 8', Viöle 8', Octave Geigen 4', Koppelflöte 4', Piccolo 2'
5. Gedackt 8', Viöle 8', Octave Geigen 4', Koppelflöte 4', Piccolo 2', Fourniture IV
6. Rohr Bourdon 8', Viöle 8', Octave Geigen 4', Koppelflöte 4', Piccolo 2', Fourniture IV, Trompette 8'

Note: Not all stops listed above may be on all organ models. Use of stops from the same stop family may be used. For example; a Koppelflöte 4' or Traverse Flute 4' may be used, a Piccolo 2' or Blockflöte 2' may be used as well as a Cymbale III or Fourniture IV. Differences in character and color should be noticed and used where appropriate when substituting stops of the same family.

The use of the *Swell to Great* and/or *Positiv to Great* coupler allows these separate ensembles to be combined on the Great manual. For example, the Great #5 and Swell #4 registrations coupled together and played on the Great combine to form a nice round hymn combination.

The Pedal ensemble is created in much the same way as the manual ensembles, starting at 16' pitch instead of 8'. Be careful that the volume of the pedals is not greater than that of the manuals. Although the manual to pedal couplers are useful in bringing clarity to the pedal line, especially on softer registrations, avoid the temptation to rely constantly on one or two 16' stops and a coupler. Please note that the softest stops and flute mutations are normally not used in ensembles.

FULL ORGAN

Due to the immense capabilities of your Allen Organ, every stop and coupler on the instrument could be used simultaneously. In good registration practice, however, the organist would not haphazardly put on every stop on the instrument. For best results, listen and include only those stops whose contribution to the fullness and brilliance of the ensemble you can hear when they are added. Eliminate soft stops and solo stops that make no audible contribution.

This short treatment barely scratches the surface of organ registration. For those interested in gaining further insight into this vital area of organ playing, we recommend the following resources:

Audsley, George Ashdown. *Organ Stops and their Artistic Registration*.
Hialeah, FL: C.P.P. Belwin, 1985.

Irwin, Stevens. *Dictionary of Pipe Organ Stops*. 2nd ed.
New York: Macmillan Books, 1983.

Cherrington, Dr. Sally. *A Church Organist's Primer. Volumes I, II, & III on a single DVD*.
Allen Organ Company.
AOC P.N: 031-00092.

VI. TRANSPOSER

The organ can perform the difficult task of transposing, while allowing the organist to play in the noted key. Operation of the Transposer is controlled by the Transposer function, found in the Console Controller. Neutral (no transposition) position is indicated by the number "0" in the Console Controller's display. To shift the music to a different key, position the cursor on the transposer value (press the **CURSOR** button on the Console Controller) and then turn the **ROTARY DIAL** in either direction. The key can be raised a maximum of five half steps and can be lowered a total of seven half steps.

A RED INDICATOR LIGHT COMES ON WHENEVER THE TRANSPOSER IS OUT OF NEUTRAL ("0") POSITION. This is to warn the organist that the instrument is not ready to play in the same key as when in the Neutral position.

Why Transpose?

- Because a song's range does not always suit the vocal range of a particular singer. By adjusting the Transposer, the piece can be sung more comfortably and effectively.
- Because some instruments are non-concert pitch. A trumpet in B^b, for example, can play the same music as the organist, if the Transposer knob is set two half steps lower.
- Because hymn singing can sometimes be improved by a more favorable key selection.

VII. VIRTUAL ACOUSTICS™

Virtual Acoustics™ provide spatial ambiance to enhance any acoustical environment. Your service technician or sales representative will adjust the Virtual Acoustics™ setting to sound best for your installation and specifically to your taste. The organist may also choose one of twenty other Virtual Acoustics™ pallets to use or it may be turned off with the switch located on the face of the Console Controller™ labeled "Virtual Acoustics™". Please refer to the Console Controller™ section in this manual regarding making changes to and selecting the various Virtual Acoustic pallets.

VIII. SOUND LIBRARY

Sound Library provides the versatility of four separate and distinct organs within a single console. Choose from Classic Allen, English Cathedral, Cavallé-Coll and Schlicker or replace the English Cathedral suite with an optional set of Theatre style samples for the stop list that perfectly complements your music. These specifications are comprised of unique pipe samples from the world's finest examples of each major organ-building style. The touch of a button changes the entire organ to the stop list of your choice! More information can be found within the Sound Library section of the Console Controller Guide later in this manual.

IX. INSTALLATION, VOICING, AND CARE OF THE ORGAN

INSTALLATION

Wherever your organ may be situated, careful installation is a prerequisite to successful results. Your Allen representative is well qualified to guide you in planning the finest possible installation. Factory assistance in planning the installation is also available and may, in fact, be sought by your Allen Organ representative.

VOICING

Your organ presents unprecedented accuracy in the scaling and voicing of each note of every stop. Should you require that these parameters be changed, your Allen Organ representative is able to help make such changes. Final adjustments in scaling and voicing involve procedures that are best left to an expert. These adjustments normally are a part of installation, and once done, should not require changes. If the organ is moved to a new location or major changes are made to the acoustical properties of the room the organ resides in, the instrument may need to be tonally finished again.

MEMORY SYSTEM

The memory for the capture system and other miscellaneous settings on your Allen Organ utilizes revolutionary "flash" technology for storage. This allows capture settings and related items to be retained in memory when the organ is switched off or unplugged. No batteries are ever required which means that regular battery maintenance, normally required every few years, has been eliminated.

CARE OF THE ORGAN

Your Allen Organ constitutes a major advance in long-term maintenance-free operation. There is no regular maintenance procedures required and, therefore, no periodic maintenance schedules to be observed.

Reasonable care will keep the instrument looking beautiful for years to come. The wood surfaces may be cleaned using a soft cloth dampened with lukewarm water. A mild solution of lukewarm water and dish detergent may be used to remove fingerprints, etc. Polish dry with a soft cloth. Do not use wax, sprays or oils on the finish. Satin finished surfaces will take on a semi-gloss appearance when waxed and will eventually become yellowed.

Keys and stop tablets should be cleaned in the following manner: Use two clean cloths. Immerse one in clear, lukewarm water and wring it thoroughly damp dry. Loosen the dirt with this cloth, and then polish immediately with the dry cloth. Do not use soap or detergent on keys or stop tablets.

To polish the clear music rack, a furniture wax polish may be sprayed on a soft dry cloth and rubbed on the front of the music rack. Keep the wax off of the wood finishes. This will help keep the music rack clear.

You have purchased a remarkable organ that not only faithfully reproduces the organ traditions of the past but also anticipates the innovations of the future. Should you have questions that are not addressed in this manual, please do not hesitate to contact your local Allen Organ representative. Welcome to the family of satisfied Allen Organ owners!

X. SAFETY INFORMATION

USA ONLY

CAUTION

Never plug the instrument into any current source other than 110 to 120 volts, 50/60 Hertz alternating current (AC). A verified grounded outlet is essential to proper operation and protection of the instrument. Proper polarity should be checked with an AC circuit analyzer before connecting the organ.

Do not change the cable plug or remove the ground pin or connect with a two-pole ground lift adapter.

If you are in doubt about your electrical connection, consult your local electrician or power company.

In facilities where circuit breakers are turned off between uses (as for example, between worship services), the circuit breaker affecting the organ console AC power should have a guard installed to prevent it from accidentally being switched off.

It is important that you read and comply with all instructions and labels that might be attached to the instrument.

INTERNATIONAL ONLY

CAUTION

Do not plug the instrument into any current source other than that stated by the selling dealer. Proper polarity should be checked with an AC circuit analyzer before connecting the organ.

Do not change the cable plug or remove the ground pin (if applicable).

If you are in doubt about your electrical connection, consult your local electrician or power company.

In facilities where circuit breakers are turned off between uses (as for example, between worship services), the circuit breaker affecting the organ console AC power should have a guard installed to prevent its being accidentally switched off.

Read and comply with all instructions and labels that may be attached to the instrument.

Warning: This equipment generates, uses, and can radiate radio frequency energy and, if not installed and used in accordance with the instruction manual, may cause interference to radio communications. It has been type tested and found to comply with the limits for a Class B Computing Device in accordance with the specifications in Subpart J of Part 15 of FCC Rules, which are designed to provide reasonable protection against such interference in a residential installation. Should this equipment cause interference to radio communications, the user at his own expense will be required to take whatever measures may be necessary to correct the interference. Whether this equipment actually causes the interference to radio communications can be determined by turning the equipment off and on. The user is encouraged to attempt to correct the interference by one or more of the following measures:

Reorient the receiving antenna.

Relocate the organ with respect to the receiver.

Move the organ away from the receiver.

Plug the organ into a different electrical outlet, so that the organ and receiver are on different branch circuits.

If necessary, the user should consult the dealer or an experienced radio technician for additional suggestions.

CE mark shows compliance with the EMC Directive.

XI. CONSOLE CONTROLLER™ GUIDE

A.	BASIC OPERATION	14
1.	Start-Up Sequence.....	14
2.	Advancing Through the Windows.....	15
3.	Selecting the Capture Memories.....	15
4.	Saving Registrations Using Pistons.....	16
5.	Locking Capture Memories.....	16
6.	Unlocking Capture Memories Using Your Code.....	17
7.	Unlocking All Capture Memories.....	17
8.	Stop Action and Capture Self Check.....	17
9.	Sound Library.....	18
10.	Virtual Acoustics™ Settings.....	19
11.	Transposer.....	20
B.	ADVANCED OPERATION	21
1.	Configuring Pistons.....	21
2.	Restoring Original Factory Settings.....	22
3.	Global Tuning.....	22
C.	MIDI FUNCTIONS	23
1.	Standard MIDI Channel Assignments.....	23
2.	Selecting Program Change Modes, Viewing Program Numbers or General Midi Sound Names.....	23
3.	General MIDI Sound Names or Program Numbers.....	24
4.	Assigning MIDI Program Changes to Organ Pistons.....	26
5.	MIDI Bank Selecting.....	27
6.	Changing the MIDI Base Channel.....	29
7.	MIDI Expression Settings.....	29
8.	MIDI Sustain Kick Switch (<i>optional</i>).....	30
9.	Transferring and Saving Capture Memory Data to a Sequencer.....	31
10.	Return Capture Memory Data from a Sequencer to the Organ.....	31
11.	Transmission/Reception of Individual Stop Data.....	32
D.	QUICK REFERENCE GUIDE	33
1.	Basic Operations Review.....	33
2.	Advanced Operations Review.....	33
E.	MIDI GUIDE.....	34
1.	MIDI for Organists.....	34
2.	Connecting Allen Organs to Other MIDI Devices.....	35
3.	Allen's Exclusive MIDI System.....	36
4.	MIDI Transmission Channels.....	36
5.	General MIDI Sound Set.....	38
APPENDIX A:	MIDI IMPLEMENTATION CHART	39

INTRODUCTION

The Console Controller™ is an interface that controls many organ functions and a variety of MIDI functions. The Console Controller is pictured below and includes a window that displays functions, one at a time, as well as an integrated Rotary Dial with push buttons used to make selections. Each window function is described in detail in this booklet.

A. BASIC OPERATION



1. Start-Up Sequence

Upon turning on the organ's main power switch the Console Controller™ will display:

```
Allen Organ Co.  
Copyright (c) 2000
```

During the start-up period do not press any keys, pedals, stops or move the expression shoe(s). You may also notice that the power LED will blink momentarily as well as the stop indicators. The organ's computer is starting up during this time period and this is considered a normal condition.

Then, the LCD window will display, in sequence:

```
DATABASE :  
XXXXXXXXXXXXXXXXXXXX
```

→

```
SMAP : XXXXXXXXXXXX  
CODE : X.XX
```

Note: The LCD will display the current database, stopmap level (SMAP) and operating software base code level (CODE) currently installed in the organ.

The organ will be ready to play when the Main window function appears on the Console Controller™ and the power LED glows steady.

2. Advancing Through the Windows

The Allen Organ operating software contains many settings that are user-programmable. Each setting can be programmed via the Console Controller's™ display. These settings are divided up into many window functions. To advance the Console Controller's™ display to the next window function, press the **CURSOR** button until the **CURSOR** is positioned under the first “M” in the abbreviation MEM within the display. Once the cursor is positioned, slowly turn the **ROTARY DIAL** clockwise, the display will advance to the next window function. When the second window function is displayed, rotate the **ROTARY DIAL** counter-clockwise, the window will return to the Main window display function. Turn the **ROTARY DIAL** counter-clockwise again and the last window function will display. The window functions “wrap around” for ease of accessing parameters quickly.

Remember: You may return to the *Main Window* function at any time by pressing and holding the **SET** piston. Then, while holding **SET**, press the **CANCEL** piston, then release both pistons. This procedure will always return the Console Controller’s display to the *Main Window* function.

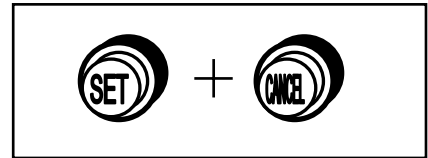

Repeat this procedure to advance through all of the windows. The last window function will display:



3. Selecting the Capture Memories

The *Main Window* function must be displayed (*See Section A-2*). Locate the **CURSOR** button on the face of the Console Controller™. Press this button to move the cursor to the first number to the right of the abbreviation “MEM” on the display. Once the cursor is positioned on the memory number, turn the **ROTARY DIAL** clockwise to select the memories sequentially from **MEM 1 to 4**. Or, turn the **ROTARY DIAL** counter-clockwise to select the memories sequentially from **MEM 4 to MEM 1**.

The capture memories allow you to save different registrations on each piston. This means **General Piston 1** on **MEM-1** may be totally different from **General Piston 1** on **MEM-2, MEM-3, etc.**

Note: A factory set of registration examples is stored on each piston of the last available capture memory. However, the factory registrations may be reprogrammed to different registrations at any time. To restore the factory registrations to the original settings, please see **RESTORING FACTORY SETTINGS** referenced later in this manual.

4. Saving Registrations Using Pistons

A **registration** is any combination of stops. These registrations can be stored (remembered) by the organ's capture memory system. The pistons provide a method to make changes quickly from one registration to another.

The L-6 is equipped with six (6) General pistons and (4) Divisional pistons for both the Swell and Great Divisions. General pistons are those which affect all stops on the organ, while Divisional pistons only affect their respective divisional stops. The General pistons are located under the Swell keyboard on the left side. The Divisional pistons are centrally located under the front of the Swell and Great keyboards on the piston rail.

To Save a Registration to a General Piston:

The *Main Window* function in the Console Controller™ must be displayed (*See Section A-2*). Select any memory number (MEM-1, MEM-2 ... MEM-4, etc.)(*see section A-3*); however, for this example use MEM-1. Next, select the desired stops you want General Piston 1 to remember. Once the selected stops are lit, press and hold the **SET** piston, then press and release General Piston 1. Finally, release the **SET** piston. General Piston 1 will now store in memory the selected stops you selected.

Note: *General Pistons are often set gradually from soft to loud with General #1 the softest and General #6 the loudest.*

To Save a Registration to a Divisional Piston:

The *Main Window* function in the Console Controller™ must be displayed (*See Section A-2*). Select any memory number (MEM-1, MEM-2 ... MEM-4, etc.)(*see section A-3*); however, for this example use MEM-1. Next, select the desired Swell division stops you want Swell Piston #1 to remember. Once the selected stops are lit, press and hold the **SET** piston, then press and release Swell Piston #1. Finally, release the **SET** piston. Swell Piston #1 will now store in memory the selected Swell division stops you selected.

5. Locking Capture Memories

All memories, except Memory 1, may be locked or unlocked individually to prevent unintentional or unauthorized changes to that memory's contents. Memory 1 remains unlocked as a convenience to visiting or substitute organists. The Console Controller must display the *Main Window* function in the drawer (*See Section A-2*). Select a capture memory to lock (*See Section A-3*). After registrations are stored to pistons, (*See Section A-4*) choose three digits you can easily remember (e.g., 1-2-3, 2-1-5, etc.). Use General Piston 1 for the 1 digit, General Piston 2 for the 2 digit and so on. Once a capture memory is selected, press and hold the **MEMORY** button in the Console Controller™. While holding **MEMORY**, press the General Pistons that correspond to your three-digit code. Release the **MEMORY** button and an "L" will appear next to the MEM number in the display, indicating this memory is now locked.

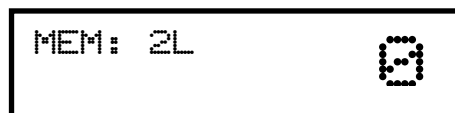

As long as the memory remains locked, the piston registrations on that memory cannot be changed. Other organisms will still be able to use the locked registrations; however they cannot be changed. Remember; choose an easy to remember three-digit code.

6. Unlocking Capture Memories Using Your Code

The *Main Window* function must be displayed (*See Section A-2*). To unlock a memory, select the capture memory to be unlocked (*See Section A-3*). Remember, locked capture memories will have an “L” behind the number. Once a capture memory is selected, press and hold the **MEMORY** button in the Console Controller™. While pressing **MEMORY**, enter the same three-digit code that was used to lock this memory (*See Section A-5*). Release the **MEMORY** button. If the correct code is entered, the “L” will disappear, indicating that this memory is now unlocked.



7. Unlocking All Capture Memories

Advance to the 'UNLOCK ALL CAPTURE MEMORIES' window function (*see section A-2*).



Press and hold the **MEMORY** button in the Console Controller™. Then, while holding **MEMORY**, press General Pistons 2-5-5. Release the **MEMORY** button. The display will automatically return to the *Main Window* function. All capture memories are now unlocked, including those memories other organisms may have locked. Registrations remain unchanged.

8. Stop Action and Capture Self Check

This feature self-checks the capture system. It tests to insure each stop is functioning properly and controllable by the capture system. Advance to the 'SELF CHECK' window function (*see Section A-2*).



To start the self-check, press the **CURSOR** button on the Console Controller to position the cursor on the word “OFF”. Turn the **ROTARY DIAL** to start the Self Check function. The display will indicate that the Self Check function is now “ON”. The stop tablets will illuminate on and off consecutively. *If a stop does not illuminate, notify your Allen service technician.* During the testing process you can interrupt and return to the *Main Window* function at any time by turning the **ROTARY DIAL** until “OFF” appears in the display or by using the **SET** and **CANCEL** pistons to return to the *Main Window* function (*see Section A-2*).

9. Sound Library

Sound Library provides the versatility of multiple distinct organs in a single console. Allen Bravura™ organs with Sound Library allow you to choose from a variety of different stop lists. The specifications are comprised of unique pipe samples from the world's finest examples of each major organ-building style. The touch of a button changes the entire organ to the stop list of your choice!

Selecting Voice Suites with the Console Controller™

Advance to the 'SOUND LIBRARY' window function (*see section A-2*).



SOUND LIBRARY
AMERICAN CLASSIC

Press the **CURSOR** button. The cursor will move to left end of the bottom row. The bottom row indicates the currently selected voice set.

Rotate the **ROTARY DIAL** until the suite name you want appears.



SOUND LIBRARY
ENGLISH

While holding the **SET** piston, press the **MEMORY** button.

The top row of the Console Controller LCD will indicate that the suite is loading and the power LED will blink.

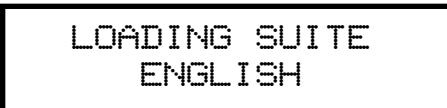

LOADING SUITE
ENGLISH

When loaded (this will take several seconds) the power LED will stop blinking and any stops that were ON will be cancelled.

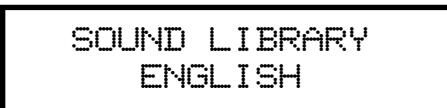

SOUND LIBRARY
ENGLISH

The organ is now ready to be played in the new voice suite.

The default voice suite at turn-on is American Classic. This selection is not settable by the organist.

To view and/or print the complete stop lists for the L-6, visit the Allen Organ Company website: www.allenorgan.com

10. Virtual Acoustics™ Settings

There are 20 Virtual Acoustic reverb pallets to select from. All 20 styles are adjustable. This allows an organist to modify the sound of the organ to accommodate a room's changing acoustical properties. (E.g., a room's natural reverberation characteristics become less reverberant as the number of people present increases. A room's reverberation time changes when a room's windows are opened or closed. It also changes with different levels of humidity)

The rocker switch labeled **VIRTUAL ACOUSTICS** on the Console Controller™ must be **ON** to hear the default reverb or one of the 20 available Virtual Acoustic selections.

The amount of reverberation may be changed on the 20 available selections.

```
ACOUSTICS:  0dB  
MEDIUM CHAMBER 3
```

The amount of reverb is shown in dB (decibels). The range of control is from 0 dB to -30 dB. -30 dB is the least amount of reverb and 0 dB is the most reverb available.

To access the Virtual Acoustic settings, advance to the 'ACOUSTICS' window function (See Section A-2).

```
ACOUSTICS:  0dB  
MEDIUM CHAMBER 3
```

The window will display: "**ACOUSTICS**" and list one of the 20 available reverb pallets on the window's second line. For example, to change to a different reverb pallet press the **CURSOR** button on the Console Controller™ until the cursor is positioned on the second line of the display and on the reverb pallet. Once the cursor is positioned, turn the **ROTARY DIAL** to select another reverb pallet. The display will also show the current amount of reverberation applied to the pallet selected.

```
ACOUSTICS:  0dB  
CATHEDRAL
```

To change the amount of reverberation applied to the selected reverb pallet, press the **CURSOR** button until the cursor is positioned on the reverb value (the decibel number). Turn the **ROTARY DIAL** to change the amount of reverberation.

```
ACOUSTICS: -20dB  
CATHEDRAL
```

Virtual Acoustic Pallets:

- | | |
|-------------------|-------------------|
| 1. Pipe Chamber 1 | 11. Large Room 3 |
| 2. Pipe Chamber 2 | 12. Small Hall 1 |
| 3. Pipe Chamber 3 | 13. Small Hall 2 |
| 4. Small Room 1 | 14. Medium Hall 1 |
| 5. Small Room 2 | 15. Medium Hall 2 |
| 6. Medium Room 1 | 16. Medium Hall 3 |
| 7. Medium Room 2 | 17. Large Hall 1 |
| 8. Medium Room 3 | 18. Large Hall 2 |
| 9. Large Room 1 | 19. Large Hall 3 |
| 10. Large Room 2 | 20. Cathedral |

11. Transposer

The organ can perform the difficult task of transposing, while allowing the organist to play in the noted key. Operation of the Transposer is controlled by the Transposer function, found within the *Main Window* of the Console Controller. Neutral (no transposition) position is indicated by the number “0” within the Console Controller’s display.



To shift the music to a different key, press the **CURSOR** button until a box appears around the transposer value.



The key can now be raised a maximum of five half steps or lowered a total of seven half steps by turning the **ROTARY DIAL** in either direction.

A red indicator light (LED) will illuminate on the Console Controller whenever the Transposer is out of the neutral (“0”) position. This is to warn the organist that the instrument is not ready to play in the same key as when in the Neutral position.

B. ADVANCED OPERATION

1. Configuring Pistons

This function enables pistons to control stops that are normally not controlled by those pistons.

Note: The piston configuration settings affect all capture memories. Separate piston configurations are NOT available on each capture memory.

For example:

(1) A General piston can be configured so that it will only affect the Tremulant stops in all divisions.

(2) A General Piston can be configured to respond like a Divisional Piston.

Note 1: Changing the configuration of a piston *will not affect the registrations* previously remembered by that piston prior to its reconfiguration.

Note 2: Reconfiguring a piston does not change its MIDI channel assignment.

Configuring a General Piston to control only the Tremulant stops:

Advance to the 'CONFIGURE PISTONS' window function (*see section A-2*).

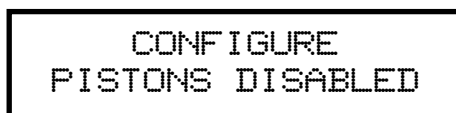

A rectangular window with a black border containing the text "CONFIGURE PISTONS DISABLED" in a monospaced font. The text is centered and arranged in two lines: "CONFIGURE" on the top line and "PISTONS DISABLED" on the bottom line.

Press the **CURSOR** button to move the cursor to the command function "DISABLED" on the 2nd line of the display. Select only the Tremulants stops. Any stops not selected, will not be able to be registered later. Then, while holding **SET**, press the General piston that you want only the Tremulants to respond to. Return to the *Main Window* to store the Tremulant registration to the General piston you pressed (*See Section A-4*).

To configure General Pistons as a Great Divisional Piston:

Advance to the 'CONFIGURE PISTONS' window function (*see section A-2*).

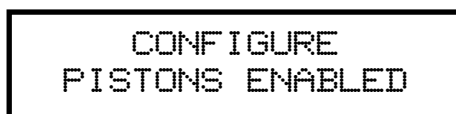

A rectangular window with a black border containing the text "CONFIGURE PISTONS ENABLED" in a monospaced font. The text is centered and arranged in two lines: "CONFIGURE" on the top line and "PISTONS ENABLED" on the bottom line.

Select *all* of the Great Division stops and the SWELL TO GREAT intermanual coupler. Press and hold the **SET** piston. Then, while holding **SET**, press the General Piston(s) you want the selected Great stops and the Swell to Great coupler to register on. Return to the *Main Window* and save registrations to those General Pistons, using combinations of Great stops and the Swell to Great coupler.

The use of the CONFIGURE PISTONS function is only limited by one's creative imagination.

Remember: The above examples only determine which stops will become accessible by the reconfigured pistons; *they will not change previously saved registrations.*

To Restore Original Factory Piston Configuration Settings:

See Section B-4 for the window function that displays:

```
RE-INITIALIZE  
PISTON CONFIG.
```

2. Restoring Original Factory Settings

Advance to the 'RE-INITIALIZE' window function (*see Section A-2*). The window will display...

```
RE-INITIALIZE  
Piston Config.
```

Certain functions can be restored to the original factory settings. They are:

```
RE-INITIALIZE  
Piston Config.
```

```
RE-INITIALIZE  
MIDI Settings
```

```
RE-INITIALIZE  
Capture Mem. XX
```

The Piston Configuration re-initialization includes all the Configure Piston settings. The MIDI Settings re-initialization includes all MIDI program change mapping. The Capture Memory re-initialization will reset the last available capture memory to factory default registrations.

Each of these functions can be restored individually. To select the factory settings you wish to restore press the **CURSOR** button until the cursor is positioned on the command function which is located on the 2nd line of the display. Press and hold the **MEMORY** button on the Console Controller. Then, while holding the **MEMORY** button, press General Pistons 2-5-5 in sequence. The display will briefly flash the word "WORKING" on the first line of the display to indicate that the current command function is being re-initialized.

3. Global Tuning

Global Tuning allows the organist to adjust the pitch of the entire organ. This tuning adjustment allows the organ to be tuned to another instrument more easily. Tuning can be adjusted either ± 100 cents from A-440 pitch. To adjust Global Tuning, advance to the 'GLOBAL TUNING' window function (*see Section A-2*).

```
GLOBAL TUNE:  
0
```

Press the **CURSOR** button until the cursor is positioned on the current tuning value (2nd line). Turn the **ROTARY DIAL** in either direction to raise or lower the pitch of the organ. The Global Tuning adjustment will be retained in memory when the organ is powered off.

C. MIDI FUNCTIONS

This section explains the MIDI capabilities of your Allen Organ. Knowledge of this section is **not** required for everyday use of the organ, normal service playing, or use of Allen SmartMIDI™ devices. This information's usefulness will ultimately be determined by your needs, along with the type and capabilities of any external MIDI devices you choose to use--e.g., sequencers, voice/sound modules and external MIDI keyboards. The MIDI topics covered by this manual are limited in scope. You need to understand the terms MIDI IN, OUT and THRU and their basic functions. To increase your understanding of MIDI you will need to read books that describe how to use MIDI.

Note: You must also consult the owner's manual that covers the external MIDI device(s) you are using for more details of their operation.

1. Standard MIDI Channel Assignments

These are the Allen Organs' standard MIDI channels settings for the L-11:

Classical Organs	
Channel	Organ Division
1	= Swell
2	= Great
3	= Pedal
8	= General

Note: The Base Channel will always reset to Channel 1 whenever the organ is turned off (see section C-5).

2. Selecting Program Change Modes, Viewing Program Numbers or General Midi Sound Names

Program change modes establish how MIDI program changes will be sent from the organ when a piston is pressed and what the resulting display will be in the Console Controller window. Once a particular program change mode is selected, the organ will retain this same program change mode (even when the organ is turned off) until a new program change mode is selected. These three mode options determine how the organ sends program change information to MIDI devices.

Selecting a Program Change Mode

Advance to the 'PROG CHG' window function (see Section A-2). It will display:

PROG CHG: USER
DISPLAY: NUMBERS

Press the **CURSOR** button until the cursor is positioned on the Program Change mode value. Turn the **ROTARY DIAL** to change and select either "Preset", "User" or "No" modes. **Note:** You must understand how to operate and when to use each of these modes before you change them!

“P” is for PRESET MODE: This mode causes the organ to send a program change number equal to the piston number that is pressed. Preset mode also allows the organ to transmit the capture memory level value whenever the capture memory level is changed or whenever the CANCEL piston is pressed. The General Pistons will send program changes 1-10 on MIDI Channel 8, the organ’s General Piston control the channel. The Divisional Pistons (1-6) for each division will send program changes 1-6 on the respective MIDI channels as shown on the previous page. For example, Swell Piston 1 will send Program Change 1 on Channel 1. Great Piston 2 will send Program Change 2 on Channel 2, etc. (See Section C-6).

“U” is for USER MODE: In this mode, the organ is capable of sending any program change number on any piston that will select voices, change banks, or change program “patch” numbers on another MIDI device. Any MIDI program change number from 1 through 128 can be assigned to any General or Divisional Piston (blank or no digit may also be selected). Any MIDI bank switch number between 0 and 127 can be assigned to any Divisional Piston. As in PRESET mode, General Pistons will send program change information on MIDI Channel 8. Divisional Pistons will send program change information on their respective MIDI channels. (See Section C-6)

Note: The capture memory level value is not transmitted while in USER mode.

“N” is for NO MODE: With this mode selected, NO information is transmitted or received. This mode cancels transmission and reception of all program change information.

3. General MIDI Sound Names or Program Numbers

The Console Controller window can display MIDI program changes as either MIDI program numbers or as General MIDI sound names. Press the **CURSOR** button until the cursor is positioned on the Display mode value. Turn the **ROTARY DIAL** to change and select one of the two modes.

General MIDI Sound Names

With General MIDI mode selected, the 'PROG CHG' window will display:

```
PROG CHG:  USER
DISPLAY:GEN MIDI
```

Make sure the word USER is selected as the mode and that GEN MIDI has been selected following the word DISPLAY. You must advance to the next window function then press a piston to view the sound names for any General MIDI device. The next window will display:

```
MIDI PROG CHANGE
```

As you press a General or Divisional Piston, the Console Controller window will now display the General MIDI sound name that corresponds to the MIDI program change selected. For example, press General Piston 1. The Console Controller will display the MIDI program change names.

Note: In some cases, the General MIDI sound name will be abbreviated in the Console Controller window.

```
GEN 1   BANK   0  
P:Ac Grand Piano
```

Program Numbers:

With NUMBERS selected as the display mode, the 'MIDI PROG CHANGE' window function will display:

```
GEN 1   BANK   0  
P: 1
```

With PRESET selected as the program change mode, press a General or Divisional Piston. The Console Controller window will display the same MIDI program change number as the associated piston pressed. For example, pressing General Piston 1 will display:

```
GEN 1   BANK   0  
P:XXX
```

The MIDI program change number will be displayed in PRESET mode, no matter if NUMBERS or GEN MIDI is displayed. You must select USER mode to view the GENERAL MIDI sound names. You must also select USER mode to assign MIDI program change numbers larger than 10 (the largest number of any piston).

With USER selected as the program change mode, along with NUMBERS as the display mode, you will be able to assign “- - -” (OFF) or any program change number from 1 through 128 to any General or Divisional Piston.

There may be a number or “- - -” following the “P:”. The “P:” represents the Program Change Number and does not stand for PRESET in this window. If there is “- - -” following “P:” this means that the “ZERO” Program Change Number will be sent from the associated piston.

To change the program change numbers, press the **CURSOR** button until the cursor is positioned on the program change number value. Turn the **ROTARY DIAL** to change the program number value.

Note: The Allen Organ uses MIDI Program Change Zero as a message for "MIDI OFF."

Important! MIDI Program Change 1 corresponds to the General MIDI sound "Acoustic Grand Piano." Some MIDI devices do not use Program Change zero for MIDI OFF. Consequently, Program Change Zero, (" - - " *within the window*) when sent from the organ, will correspond to Program Change 1 on those MIDI devices. Program Change 1 sent from the Allen will correspond to Program Change 2 on those MIDI devices etc. You must also consult the owner's manual that covers the external MIDI device(s) you are using for more details of their operation.

4. Assigning MIDI Program Changes to Organ Pistons

This function allows the organist to select any voice from an external MIDI device by pressing any General or Divisional piston on the organ. The "USER" program change mode must be selected (*See Section C-2*). Advance to the 'MIDI PROG CHANGE' window function (*see Section A-2*).

```
MIDI PROG CHANGE
```

For this example press the Swell Division Piston 1. The display will change to:

```
SW 1   BANK  0  
P:  1
```

The LCD will display the last piston pressed and the MIDI program number being sent by that piston. Press the **CURSOR** button until the cursor is positioned on the program change number value. Turn the **ROTARY DIAL** to change the program number value. A program number of (1-128) will be transmitted on the channel assigned to the division from which you selected the piston; in this case, the Swell Division on Channel 1. (*See Section C1*).

```
SW 1   BANK  0  
P:128
```

Note: Reconfiguring a Divisional Piston to become a General Piston will NOT change the MIDI channel it transmits on. Also, refer to the program number chart in the owner's manual of the external MIDI device you are using. Once you have assigned a MIDI program change number to a piston, that number will remain assigned to that piston even if the organ has been turned off.

Important! Once MIDI program change programming is complete the user must exit the piston programming window function, by using the **SET** and **CANCEL** pistons (*see Section A-2*), for any changes to take effect.

5. MIDI Bank Selecting

Many MIDI devices permit access to a variety of sounds in addition to the General MIDI sounds. Normally these additional sounds are stored in groups called BANKS. A BANK in MIDI terminology means a group of voices or sounds. There are two levels of banks. One level offers two choices, High Bank and Low Bank. Each of these, High Bank and Low Bank, has as sub-groups other level of banks, BANK Numbers.

MIDI devices can have as many as 128 sounds/voices per BANK Number. There are also 128 BANK Numbers (Ø through 127). Therefore it is possible that a MIDI device that is only High Bank or Low Bank compatible. With 128 BANK Numbers, each could contain up to 128 voices/sounds, for a total of 16,384 sounds. Think of these BANK Numbers as floors or stories in a tall building. Each floor would contain 128 rooms and each room could then contain 128 voices.

There are MIDI devices that are High Bank and Low Bank compatible. It would be possible for these MIDI devices to have as many as (128 X 128 X 2 = 32,768 voices/sounds) 128 voices/sounds in each of the 128 BANK Numbers, in each of the High and Low Banks. Most MIDI devices do not use all of the locations available. It would be very expensive as well as difficult to remember the address for each sound location. There are also MIDI devices that offer only General MIDI sounds/voices. These General MIDI devices may operate using High Bank or Low Bank, but only the sub-group Ø Bank Number is used to store the 128 General MIDI sound settings. Allen Organs are able to access any of the Banks and therefore can communicate with all MIDI devices.

Note: You MUST know the capabilities of, and understand how to operate, the MIDI device you intend to use with any organ!

Selecting High Bank or Low Bank:

Advance to the 'MIDI BASE CHANNEL' window function (*see Section A-2*).

```
MIDI BASE CH: 1
BANK: LOW
```

Press the **CURSOR** button until the cursor is positioned on the BANK select value. Turn the **ROTARY DIAL** to select either HIGH or LOW Bank priority.

Selecting MIDI Bank Numbers:

Bank Numbers are assignable in the same way that MIDI Program Numbers are (*See Section C-3*); except that you must only use Bank numbers on the Divisional Pistons. You must have USER mode selected before assigning Bank numbers!

Advance to the 'MIDI PROG CHANGE' window function (*see Section A-2*).

```
MIDI PROG CHANGE
```

```
GT 1   BANK  0  
P:  1
```

For this example press the Great Division Piston 1. The display will change to:

The window displays the last piston pressed, the MIDI BANK Number, and the program number being sent by that piston. Press the **CURSOR** button until the cursor is positioned on the MIDI Bank number value. Turn the **ROTARY DIAL** to select or change the MIDI BANK number value. The BANK number (0-127) will be transmitted on the channel assigned to the division from which you selected the piston, in this case, the Great Division on Channel 2 (*See Section C-1*). Also, refer to the Bank selection/program number chart in the owner's manual for the external MIDI device you are using.

Once you have assigned a MIDI BANK Number to a piston, that number will remain assigned to that piston even if the organ has been turned off.

Important! Once MIDI Bank change programming is complete the user must exit the piston programming window function, by using the **SET** and **CANCEL** pistons (*see Section A-2*), for any changes to take effect.

6. Changing the MIDI Base Channel

This function allows you to change the setting of the MIDI Base Channel. The Base Channel is a reference point to establish the positioning of the other 15 MIDI channels. On Allen Organs, the Base Channel equals the Swell Division's channel of transmission (i.e., if the Base Channel = 1, then the Swell Channel = 1, if the Base Channel = 2, then the Swell Channel = 2, etc.). Changing the Base Channel allows you to shift the organ's range of MIDI channels, this is helpful when reassigning an external MIDI device from one organ division to another.

Important! The Base Channel always resets to Channel 1 whenever the organ is turned on.

Advance to the 'MIDI BASE CH' window function (*see Section A-2*).

```
MIDI BASE CH:  1
BANK: Low
```

Press the **CURSOR** button until the cursor is positioned on the MIDI Base Channel value. Turn the **ROTARY DIAL** to change the MIDI Base Channel value. All functions associated with a particular division will transmit and receive on its assigned channel. For example, MIDI Channel 1 is normally assigned to the Swell Division and the Swell Manual. Therefore, keying velocity or on/off messages, and program changes (Swell Divisional Pistons) will be transmitted and received on Channel 1 (*See Section C-1 for Allen MIDI Channel Assignments*).

If the Base Channel is set to 2, all of the channels will shift higher by one. Now, Swell = 2, Great = 3, Pedal = 4 and the General Pistons = 9. **Note:** MIDI Channel numbers will wrap, i.e. channel numbers go only to 16 and will then repeat to 1.

Important! For normal use, do not use a base channel larger than 9.

7. MIDI Expression Settings

Advance to the 'MIDI EXPRESSION' window function (*see Section A-2*).

```
MIDI EXPRESSION
POLY-VOLUME
```

There are four modes for transmitting expression data via MIDI. To select an expression mode, press the **CURSOR** button until the cursor is positioned on the expression setting value (line 2) of the display. Turn the **ROTARY DIAL** to select one of the four different expression modes.

Note: The default expression mode setting is always POLY-VOLUME.

POLY-VOLUME — This is the normal expression mode setting where the expression data is distributed among the appropriate MIDI channels. This is the proper mode to use when recording to, or playing back from, a sequencer.

POLY-VELOCITY — This setting should be selected if you are using a percussion-type voice from a sound module or an external MIDI keyboard. For example, if a digital piano sound were played from the organ keyboard through MIDI Channel 1, the piano could be made to sound more realistic. By opening the Swell expression shoe, the piano strings would appear to be struck harder than when the Swell pedal was in the closed position.

Note: This mode setting should only be used if your Allen Organ does not contain velocity sensitive keying.

Note: In POLY-VELOCITY mode, all expression information is sent in key velocity form. Changes in velocity will occur only when a new key is struck. Consequently, if you change the position of the Swell pedal after a key is struck there will be no change in velocity until a new key is struck. Use this mode only when a velocity-sensitive external MIDI device is connected. If this mode is selected when recording to a sequencer, the expression on the organ will not function when playing back from the sequencer.

SWELL-VOLUME — This setting causes MIDI expression data to be sent only on the Swell MIDI channel. Some early sequencers can only interpret one volume message.

NO EXPRESSION — No MIDI expression (volume) data sent.

8. MIDI Sustain Kick Switch *(optional)*

A lever located to the left of the expression shoe and controlled by the organist's foot, operates MIDI sustain. This function can be assigned to any one of or all of the instrument's manuals. Advance to the 'MIDI SUSTAIN' window function (*see Section A-2*).

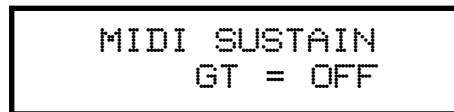

```
MIDI SUSTAIN
GT = OFF
```

To select an organ keyboard (manual), press the **CURSOR** button until the cursor is positioned on the manual abbreviation. Turn the **ROTARY DIAL** to select an organ keyboard. Then, to turn the MIDI Sustain function on/off on the selected manual, press the **CURSOR** button until the cursor is positioned on the MIDI Sustain value. Turn the **ROTARY DIAL** to turn the selected manual **ON/OFF**. **OFF** will not allow MIDI Sustain messages to be transmitted, **ON** will allow MIDI sustain messages to be transmitted on a given keyboard (manual) or MIDI channel. For example, when a **PIANO** voice in an external MIDI device (voice module) is selected and the MIDI sustain for that given MIDI channel (division) is turned **ON**, and the foot controlled sustain lever is actuated, the piano sound will slowly decay.

9. Transferring and Saving Capture Memory Data to a Sequencer

CAPTURE MEMORY refers to all of the piston registrations on all available memories, plus all positional secondary Crescendo “B” settings and the secondary Tutti “B” settings. With this operation, the organist can copy and save all of this stored information to a digital MIDI sequencer. Advance to the 'CAPTURE MEMORY SAVE' window function (*see Section A-2*).

```
CAPTURE MEMORY  
SAVE
```

Set your sequencer to the record mode and begin recording as you normally would. Press and hold the **MEMORY** button in the Console Controller. While holding **MEMORY**, press General Pistons 2-5-5 in sequence. The Capture Memory information will be transmitted to the sequencer. During the memory data transfer process the window will display:

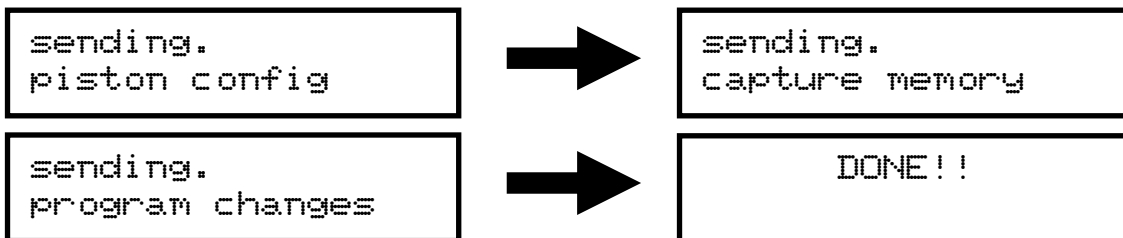

The 'dot' behind the word 'SENDING' on line one of the display will move as the data is transmitted.

Once completed, a copy of the Capture Memory information will exist within the sequencer and the original information will be retained in the Console Controller memory.

10. Return Capture Memory Data from a Sequencer to the Organ

To replace previously recorded Capture Memory information into the organ from your sequencer, simply press "Play" on the sequencer and the recorded capture data will automatically be transmitted to the organ. You must have a MIDI cable connected from the OUT port of the sequencer to the IN port of the Allen Organ. It does not matter what window function the Console Controller displays.

Note: The Capture Memories must be unlocked (*see section A-6*) before you press “Play” on the sequencer, allowing the organ’s available memories to receive capture information. It is a good idea to first save whatever is stored in the organ’s memory because, it will be erased by this procedure.

```
RECEIVING DATA  
* *
```

Note: The 'dot' on line two of the display will move as data is received.

11. Transmission/Reception of Individual Stop Data

This function allows the organist to turn on/off the transmission and reception of individual stop data, known in MIDI terminology as "Non-Registered Parameter Numbers". In some cases individual stop data (on/off) from the organ may conflict with data from an external MIDI device. When this occurs, select the "OFF" position.

Note: Piston changes will still be transmitted and received, because they are classified as program changes.

Advance to the 'TRANSMIT / RECEIVE STOPS' window function:



```
TRANSMIT/RECEIVE
STOPS ON
```

To change the on/off status of the Transmit/Receive Stops function, press the **CURSOR** button until the cursor is positioned on the status control value. Turn the **ROTARY DIAL** to turn the transmit/receive status on/off.

D. QUICK REFERENCE GUIDE

1. Basic Operations Review

a. Advancing Through the Windows:

Use the **ROTARY DIAL** in the Console Controller.

b. Return to the Main Window function:

Hold **SET**, press **CANCEL**, release both or use the **ROTARY DIAL** in the Console Controller.

c. Setting Pistons:

Main Window. Select desired registration. Hold **SET** and press piston to remember registration.

d. Select Memory and Lock It:

Main Window. Select desired memory using **CURSOR** button and **ROTARY DIAL**. Press and hold **MEMORY** button, enter three-digit code on general pistons, release **MEMORY**, "L" will appear next to capture memory number in display.

e. Unlock a Memory:

Repeat d. above. "L" will disappear.

f. Unlock All Memories Without Code:

Advance to display "Unlock All Capture Memories". Press and hold **MEMORY**, press General Pistons 2-5-5, release **MEMORY**. Display returns to *Main Window* function.

g. Self-Check Capture and Stop Action:

Advance to display: "Self-Check". Turn **ROTARY DIAL** to activate/de-activate Self-Check or to de-activate, press and hold **SET**, press **CANCEL**, and then release both.

2. Advanced Operations Review

a. Reconfiguring Pistons:

Advance to display: "Configure Pistons". Select the desired stops. Press and hold **SET**, and then press the desired piston. To return to the *Main Window*, (press and hold **SET**, press **CANCEL** and then release both). Set new registrations (*see section E-1, c.*).

b. Restore Factory Settings:

Advance to display: "Re-Initialize Piston Configuration". Use **CURSOR** button and **ROTARY DIAL** to select the settings you want to restore. Press and hold **MEMORY**, press General Pistons 2-5-5.

E. MIDI GUIDE

1. MIDI for Organists

The term MIDI is an acronym for Musical Instrument Digital Interface. MIDI has been adopted by the music industry as a standard means of communication between digital musical devices enabling devices of different types and manufacturers to communicate. MIDI by itself will not make a sound. It is not necessary to understand all of the technical aspects of MIDI in order to take advantage of the benefits it offers. It is important to explore the potential MIDI holds for musicians, as well as the various MIDI applications available today.

Types of MIDI Devices

MIDI devices fall into two categories.

1. The first category consists of musical instruments such as organs and synthesizers that transmit and receive MIDI data.
2. The second category includes controllers and processors that, as their name implies, can transmit, receive or manipulate MIDI data, but do not necessarily produce sound themselves. Sequencers, which are MIDI recording devices, fall into this category. Although the technical nature of their recording and editing processes differs from those of a tape recorder, many operate in similar fashion. Most are equipped with record, playback, fast forward and reverse controls that function in the same way as their tape recorder counterparts.

Types of MIDI Data

There are several types of MIDI messages that can be sent from one device to another. The most common is keying information, allowing one device to sense which keys have been played on another device. This means an organ equipped with MIDI can send information to other MIDI devices, e.g., synthesizers or sequencers, and can play those devices simultaneously or record information to be played back later.

Allen Organs incorporate an advanced MIDI system allowing the transmission and reception of all types of MIDI information (velocity keying, volume change, sustain, registrations, Crescendo settings and more). It is even possible to control several devices from one manual simultaneously, or control a different device from each manual of the console.

MIDI as a Practice Tool

For the organist/choir director, the MIDI organ console and sequencer are valuable rehearsal tools for both choral and organ works. Anthem accompaniments may be recorded in advance and played back by the sequencer during choir rehearsal. The director, freed from the role of accompanist, can focus entirely on directing the choir. The sequencer can play the music back at a slower tempo without affecting pitch, or at a lower pitch without affecting tempo, features that are useful in rehearsing difficult choral passages.

If the sequencer allows multi-tracking, each vocal section's part may be recorded on a different track, and then played back individually, or in any combination, for more flexibility. Multi-tracking can also be used in teaching and learning new organ works. The teacher may record each hand or pedal part on a different track, allowing the student to "mute" or turn off any part being practiced while still being able to hear the sequencer play the rest of the composition. The student's ability to hear the piece in its entirety from the earliest stage of learning a composition, and to become aware of the interrelationship of its voices, is especially valuable in learning contrapuntal works.

MIDI as a Registration Tool

In some churches and auditoriums it is difficult to judge the effectiveness of a registration from the organ console. Due to the acoustics of the room, or positioning of the console, the sound of the instrument may be different when listened to from the congregation's or audience's vantage point. MIDI allows the organist to evaluate registrations by recording the music using a sequencer, and then listening from different locations in the room during the music's playback.

Other MIDI Uses

MIDI has created new possibilities for the organist. The ability of the organ console to control external keyboards or sound modules puts an ever-increasing array of non-traditional sounds at the organist's fingertips. A superior degree of control is made possible by the flexibility of an organ console. The ability to record MIDI data using a sequencer opens a variety of new possibilities during practice and performance situations.

Computer software programs are also available that allow musicians to play MIDI devices connected to a computer, and have their performance printed as conventional five-line musical notation. Because MIDI is an industry-wide standard, today's MIDI instruments will be compatible with tomorrow's MIDI innovations.

2. Connecting Allen Organs to Other MIDI Devices

Allen Organs can be connected to a variety of MIDI devices. A connecting diagram for a variety of MIDI devices can be found at the end of this section. Although the diagram is not meant to be an exhaustive list of possibilities, it illustrates the most commonly used connections of MIDI devices. If more specific information is required, please consult the owners' manuals of the external devices being connected to the organ.

3. Allen's Exclusive MIDI System

Allen Organs feature an advanced MIDI system with increased flexibility. This system provides a comprehensive interface between MIDI sound modules, such as the Allen Ensemble™, and digital sequencers such as the Allen MIDI Assistant™. Two MIDI Out ports, one switched and one unswitched, allow unprecedented control over external MIDI devices attached to the organ.

Under normal circumstances, MIDI sound modules should be connected to the switched MIDI port labeled MIDI OUT 2. Doing so allows the organist to control the sending of MIDI keying data from the organ to the sound module by using the MIDI stop controls. Devices such as MIDI sequencers should be connected to the un-switched MIDI port labeled MIDI OUT 1, eliminating the necessity of having to draw the MIDI stop controls before recording a digital sequence. The drawing below illustrates the proper procedure for connecting the Allen Ensemble™ and Allen MIDI Assistant™ to an Allen Organ.

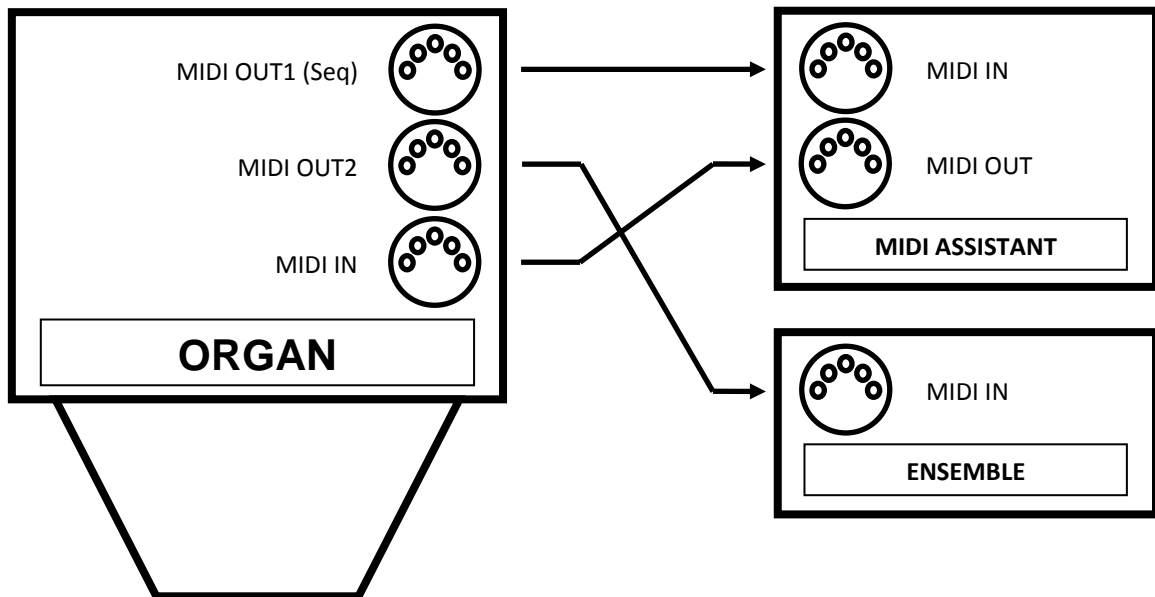

4. MIDI Transmission Channels

MIDI information may be transmitted on several different channels simultaneously. This allows many channels of information to be sent through one cable and used independently from one another, similar to the way many television broadcasts can be sent through one cable. In order to receive the intended information, a MIDI device must be tuned to the same channel as the device that is sending the information.

Your Allen Organ transmits MIDI information on several channels. When external MIDI devices are connected to the organ, it is important to make sure that the devices' channels of transmission and reception match the MIDI channels of the Allen Organ divisions to which they are assigned.

MIDI Program Change Messages are transmitted from the organ's General Pistons on MIDI Channel 8. These program change messages can be used to change the settings of MIDI sound modules or synthesizers that are connected to the organ. Please consult the owner's manual of your MIDI device(s) for more information on how MIDI Program Change Messages are handled by that particular device.

In addition to keying and divisional registration information, MIDI Volume Messages are sent on the individual MIDI channels for each division of the organ. These volume messages are controlled by the division's expression shoe. In this manner, the volume of connected MIDI devices may be controlled.

Please consult the owner's manual of your MIDI device(s) for more information on how MIDI Volume information is handled by that device. If any external MIDI device is used to transmit information to the Allen organ, the same assignment of MIDI channels must be used as described elsewhere in this manual.

5. General MIDI Sound Set

1. Acoustic Grand Piano
2. Bright Acoustic Piano
3. Electric Grand Piano
4. Honky-tonk Piano
5. Rhodes Piano
6. Chorused Piano
7. Harpsichord
8. Clavinet
9. Celesta
10. Glockenspiel
11. Music Box
12. Vibraphone
13. Marimba
14. Xylophone
15. Tubular Bells
16. Dulcimer
17. Hammond Organ
18. Percussive Organ
19. Rock Organ
20. Church Organ
21. Reed Organ
22. Accordion
23. Harmonica
24. Tango Accordion
25. Acoustic Guitar (nylon)
26. Acoustic Guitar (steel)
27. Electric Guitar (jazz)
28. Electric Guitar (clean)
29. Electric Guitar (muted)
30. Overdriven Guitar
31. Distortion Guitar
32. Guitar Harmonics
33. Acoustic Bass
34. Electric Bass (finger)
35. Electric Bass (pick)
36. Fretless Bass
37. Slap Bass 1
38. Slap Bass 2
39. Synth Bass 1
40. Synth Bass 2
41. Violin
42. Viola
43. Cello
44. Contrabass
45. Tremolo Strings
46. Pizzicato Strings
47. Orchestral Harp
48. Timpani
49. String Ensemble 1
50. String Ensemble 2
51. SynthStrings 1
52. SynthStrings 2
53. Choir Aahs
54. Voice Oohs
55. Synth Voice
56. Orchestra Hit
57. Trumpet
58. Trombone
59. Tuba
60. Muted Trumpet
61. French Horn
62. Brass Section
63. Synth Brass 1
64. Synth Brass 2
65. Soprano Sax
66. Alto Sax
67. Tenor Sax
68. Baritone Sax
69. Oboe
70. English Horn
71. Bassoon
72. Clarinet
73. Piccolo
74. Flute
75. Recorder
76. Pan Flute
77. Bottle Blow
78. Shakuhachi
79. Whistle
80. Ocarina
81. Lead 1 (square)
82. Lead 2 (sawtooth)
83. Lead 3 (caliope lead)
84. Lead 4 (chiff lead)
85. Lead 5 (charang)
86. Lead 6 (voice)
87. Lead 7 (fifths)
88. Lead 8 (brass + lead)
89. Pad 1 (new age)
90. Pad 2 (warm)
91. Pad 3 (polysynth)
92. Pad 4 (choir)
93. Pad 5 (bowed)
94. Pad 6 (metallic)
95. Pad 7 (halo)
96. Pad 8 (sweep)
97. FX 1 (rain)
98. FX 2 (soundtrack)
99. FX 3 (crystal)
100. FX 4 (atmosphere)
101. FX 5 (brightness)
102. FX 6 (goblins)
103. FX 7 (echoes)
104. FX 8 (sci-fi)
105. Sitar
106. Banjo
107. Shamisen
108. Koto
109. Kalimba
110. Bagpipe
111. Fiddle
112. Shanai
113. Tinkle Bell
114. Agogo
115. Steel Drums
116. Woodblock
117. Taiko Drum
118. Melodic Tom
119. Synth Drum
120. Reverse Cymbal
121. Guitar Fret Noise
122. Breath Noise
123. Seashore
124. Bird Tweet
125. Telephone Ring
126. Helicopter
127. Applause
128. Gunshot

APPENDIX A: MIDI IMPLEMENTATION CHART

FUNCTION		TRANSMITTED	RECEIVED
Basic Channel	Default Changed	1 1 – 16	1 1 – 16
Mode	Default Messages Altered	3 X X	3 X X
Note Number		O (1 – 127)	O (1 – 127)
Velocity	Note ON Note OFF	9nH, v = 1 – 127 9nH, v = 0	9nH, v = 1 – 127 9nH, v = 0
Aftertouch	Keys Channels	X X	X X
Pitch Bend		X	X
Control Change	0 (bank select) 6 (data) 7 (volume) 64 (sustain) 98 (NRPN MSB) 99 (NRPN LSB)	O O O O O O	O O O O O O
Program Change		O (1 – 127)	O (1 – 127)
System Exclusive		O	O
System Common		X	X
System Real Time		X	X
Aux Messages		X	X

Mode 1: Omni On, Poly
Mode 3: Omni Off, Poly

Mode 2: Omni On, Mono
Mode 4: Omni Off, Mono

O: Yes
X: No